

**Range:** Deck-mounted mixer sensor tap - PRESTOGREEN RANGE

**Ref:** 55385 - PRESTO NOVA Mixer - PRESTOGREEN

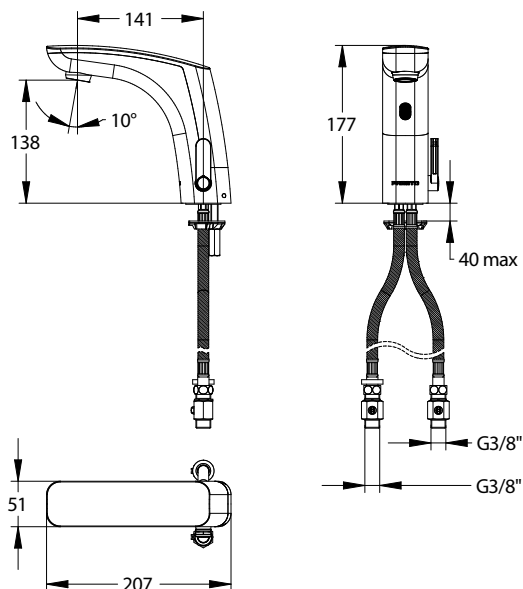

#### > Working pressure :

- 1 to 5 bar

#### > Flow :

- 1,9 l/min with integrated flow limiter sprayer
- High quality anti-limescale aerator
- Anti-water-hammering device

#### > Hydraulic supply :

- G 3/8" (12x17)

#### > Power supply :

- Integrated 6V CRP2 lithium battery in a waterproof case, located inside the tap body.

#### > Material and colour finish :

- Injected molded metal body
- Chrome plated cover

#### > Thermal resistance :

- Resistant to a temperature of 75°C for 30 minute thermal shocks

#### > Security :

- Maximal limited temperature by ajustable temperature limiter device
- The solenoid valve will be closed automatically in case of over flow (>30 seconds), low battery or any damage of detector
- Patented anti-blocking "S" system to avoid the water to flow continuously

#### > Delivered with :

- 1 Brass clamping nut
- 1 Gasket and 1 Washer
- 2 PEX Hoses with revolving nuts and NF check valves
- 2 Filter gaskets
- 1 Self-adhesive sticker
- Instruction manual

#### > Standards & approvals :

- Brass in accordance with EN1982, EN12164, EN12165
- 200-hour neutral salt spray resistant (NSS) in accordance with ISO 9227

